

Olympus

UNIVERSAL ILLUMINATOR
MODEL **LSD**
WITH TRANSFORMER TC

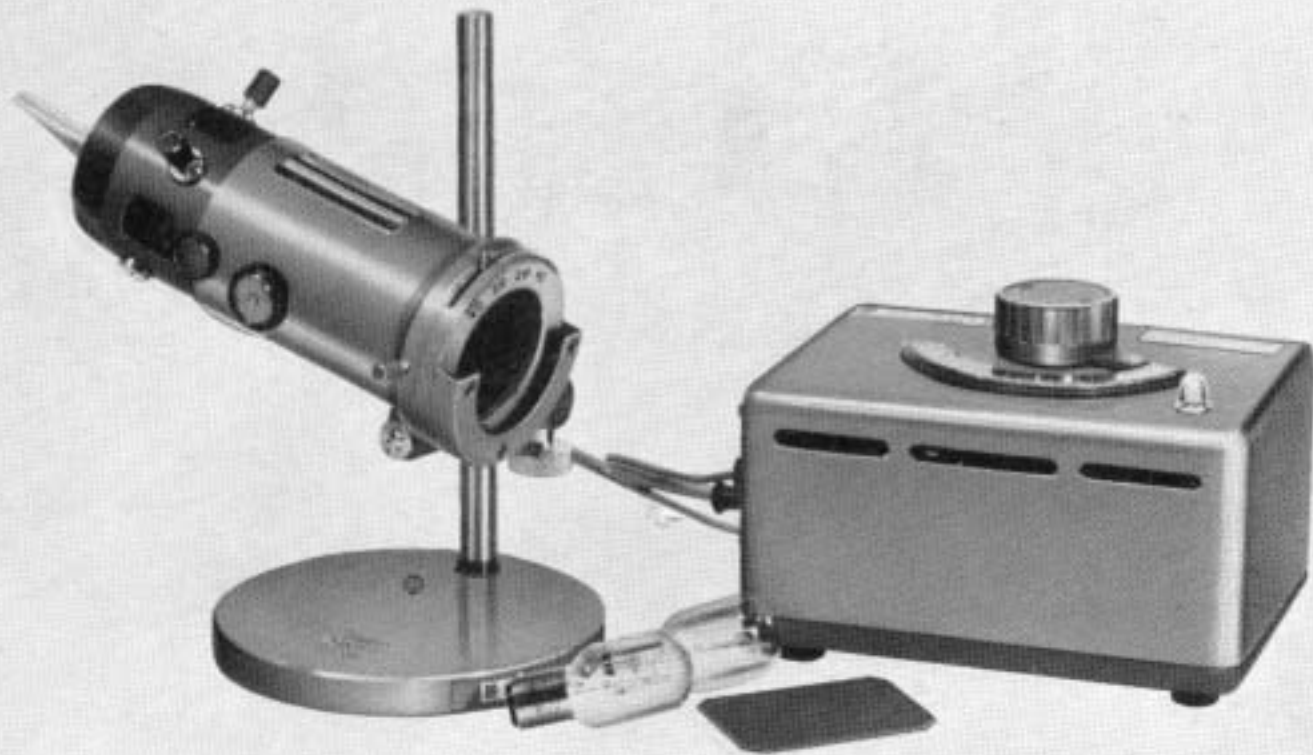

NAME OF PART

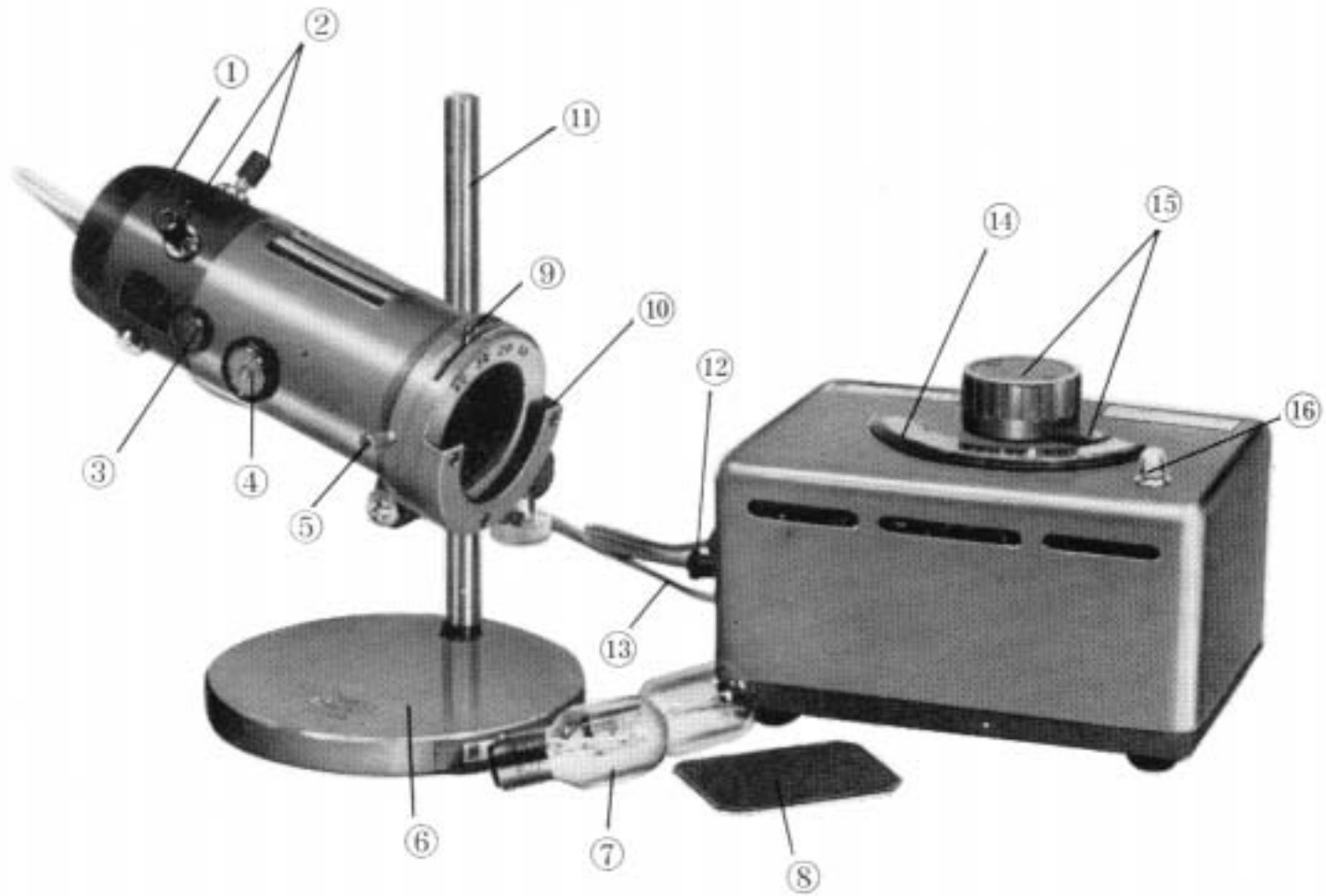

1. Lamp socket
2. Centering screws
3. Clamp screw for locking the lamp house
4. Lamp house condenser focusing adjustment knob
5. Field diaphragm locking screw
6. Base
7. Spare bulb
8. Filter
9. Field diaphragm adjustment lever
10. Filter holder
11. Column
12. Secondary output
13. Primary input
14. Voltage scale mark (white and red zones)
15. Voltage adjustment handle
16. Pilot lamp

FEATURES

- Vertical movements and rotation of the illuminator along the column can be adjusted as required.

Vertically.....range of 150 mm

Rotation360°

- Ventilated lamp house insures long bulb life.
- The 18mm travel of the condenser rack and pinion permits adjustment of the light beam to converging, diverging and parallel, as desired.
- Field diaphragm, on which filter holder is provided, can easily be removed and replaced. Diaphragm is adjustable from 2-42mm.
- Centering is easy by means of the two centering screws.
- Rated voltage : 6V. 5A (flat filament)
- Color temperature : Approximately 2,800°K at around 7.5V.

HOW TO OBTAIN KOHLER ILLUMINATION

Microscope used.....Model GB
Objective10X

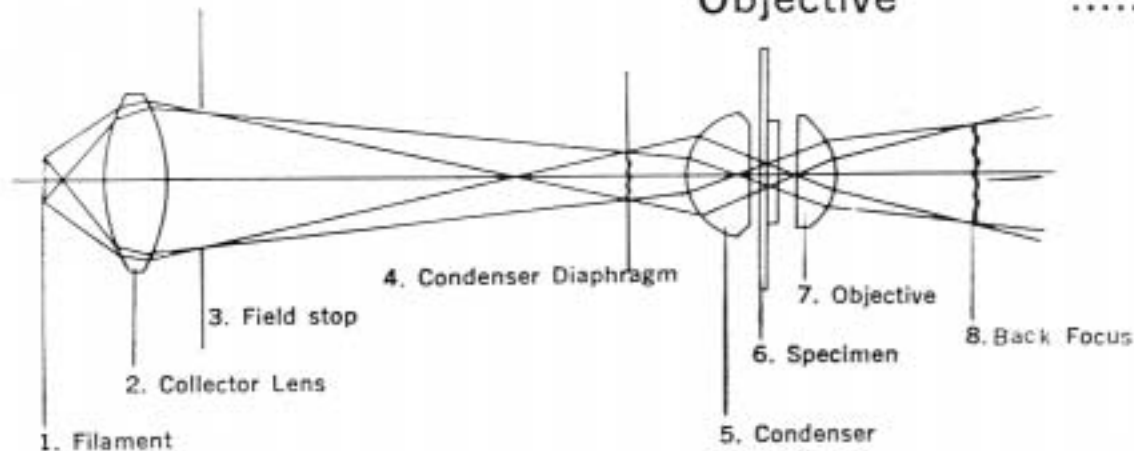

1. Close condenser diaphragm of the microscope.
2. Set the mirror of the microscope with its plane surface upward.
3. Place the LSD illuminator facing the microscope. (The distance between the microscope and illuminator varies from 15-50cm according to the type of objective used. Namely, with the low power objective, place the illuminator close to the microscope, and with the high power objective, place it further from the microscope).

4. Look at the mirror and set the image of filament to the center of the condenser diaphragm on the mirror by adjusting the angle of the illuminator.
5. Open the condenser diaphragm.
6. While looking through the eyepiece, close the field diaphragm of the illuminator to an aperture to produce a ring within the field.
7. Focus the ring by moving the condenser of the microscope up and down.
8. Bring the ring to the center of the field by adjusting the mirror.
9. Open the field diaphragm of the illuminator.
10. Remove the eyepiece.
11. Close the condenser diaphragm.
12. While looking through the eyepiece tube, focus the diaphragm (small ring) by the condenser adjustment knob.
13. Look at the mirror and set the image of filament to the center of condenser diaphragm on mirror by means of the two centering screws of the illuminator.
14. Replace the eyepiece.
15. Now you have obtained Köhler illumination.

IMPORTANT :

Once Köhler illumination has been obtained **DO NOT MOVE** either the microscope, illuminator, or mirror. Movement of any of these will impair Köhler illumination, and you will have to start from the beginning again.

NOTES :

1. With low power objective, particularly with the 4X objective, the field is often illuminated unevenly. In this case, adjust the lighting in the following manner.
 - (a) First obtain Köhler illumination with the 10X objective according to the mentioned procedure, then switch to the 4X objective by rotating the nosepiece.
 - (b) Remove the condenser, screw off the top lens and return the condenser to its mount.
2. Condenser.

The numerical aperture of Olympus two-lens condenser is 1.25 when oil is used for oil immersion microscopy, otherwise it is N. A. 1.0—0.9, and N. A. 0.65 without the top lens.

HOW TO OBTAIN CRITICAL ILLUMINATION

This illumination is most desirable for observation with the 100X objective.

1. First obtain Köhler illumination with the 10X objective according to the procedure described above.
2. Switch to the 4X objective by rotating the nosepiece.
3. While looking through the eyepiece, produce a clear image of filament on the center of the image of specimen by means of the lamp house condenser focusing adjustment knob of the illuminator.
4. Now you have obtained critical illumination.
5. Change objective to higher magnification as desired by rotating the nosepiece.

NOTE : When objective is changed to a higher magnification the image of filament is no longer seen in the field. However, as long as the image of the filament is sharp focus with the 4X objective you are observing under critical illumination.



OLYMPUS OPTICAL CO., LTD.

3 - 7 Kanda-Ogawamachi, Chiyoda-ku, Tokyo, Japan